

IMMS-SI

Communications Site Interface

Installation Instructions

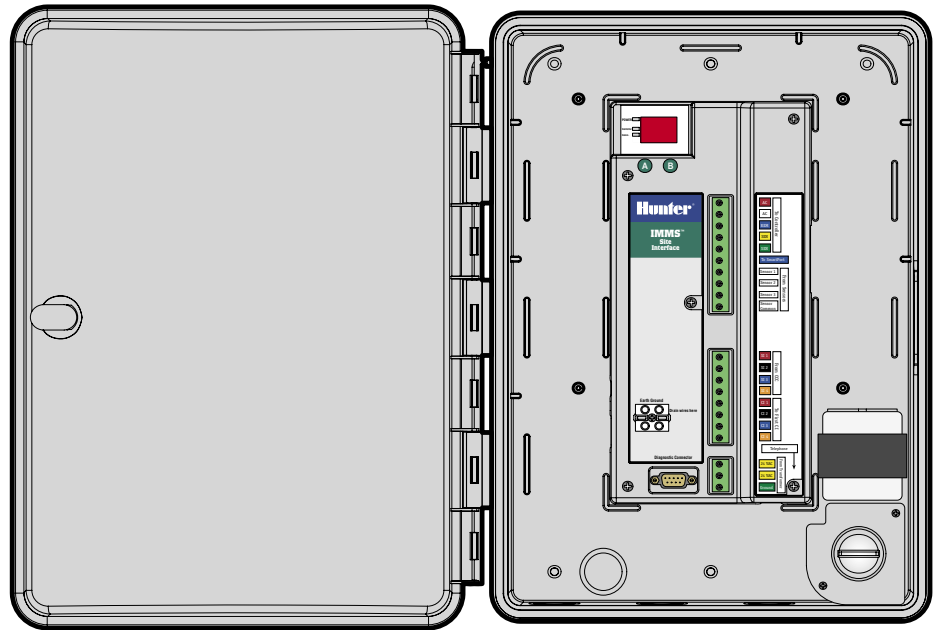

Hunter[®]

TABLE OF CONTENTS

| | |
|--|----|
| Mount the Cabinet | 1 |
| Connect AC power | 2 |
| Connect Interface to Controller | 3 |
| Connect Interface to ICC | 3 |
| Connect Interface to Pro-C and SRC | 4 |
| IMMS-SI Communications Connections | 5 |
| Hardwire connection (IMMS-SI-HW) | 5 |
| Telephone Modem connection (IMMS-SI-MOD)..... | 6 |
| Wireless Connection | 6 |
| Earth Grounding | 7 |
| Power and Test..... | 7 |
| A & B Buttons | 8 |
| To Address Controller Interfaces | 8 |
| Diagnostics | 9 |
| Additional Connections | 9 |
| Connections to Other Interfaces | 10 |
| Connection to optional Clik sensors | 10 |
| Powered sensors | 11 |
| Wireless Rain-Clik™ | 11 |
| Flow-Clik IMMS | 12 |
| Connection to optional remote receiver (SRR or ICR)..... | 13 |
| GCBL | 14 |
| 5 conductor sprinkler wire | 14 |
| RJ-11 Telephone cable..... | 14 |

MOUNT THE CABINET.....

Choose a dry, flat location on a suitable indoor or outdoor wall, which will not receive spray from sprinklers. Telephone modem Site Interfaces (IMMS-SI-MOD) must be located within 6 ft. (2 m) of the telephone jack. Drive self-tapping screws through recessed holes in plastic cabinet back into solid surface. Ambient operating temperature must not exceed 120°F (50°C).

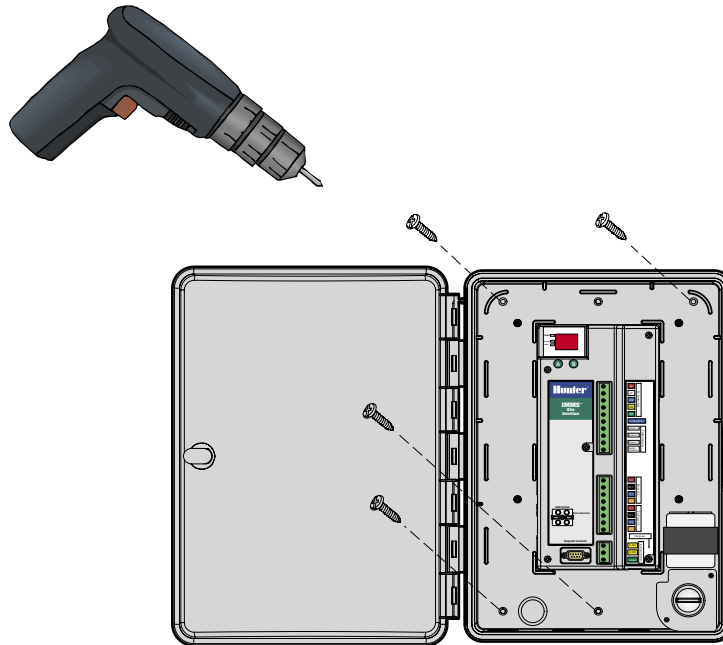

CONNECT AC POWER

1. Verify that AC power is switched OFF at the power source before beginning.
2. Remove the junction box cover (two screws).
3. Use appropriate electrical conduit and fittings to route AC power wire into the junction box. Run high voltage power wiring in separate conduit from low voltage signal wiring.

4. Connect the power wires to the transformer wires with wire nuts (see color code chart), and replace junction box cover.
5. Installer is responsible for local electrical codes and wiring.

| Transformer | Hot | Neutral | Safety Ground (required) |
|-------------------------------|-------|---------|--------------------------|
| North America (115VAC) | Black | White | Green |
| International (230VAC) | Brown | Blue | Green with yellow stripe |

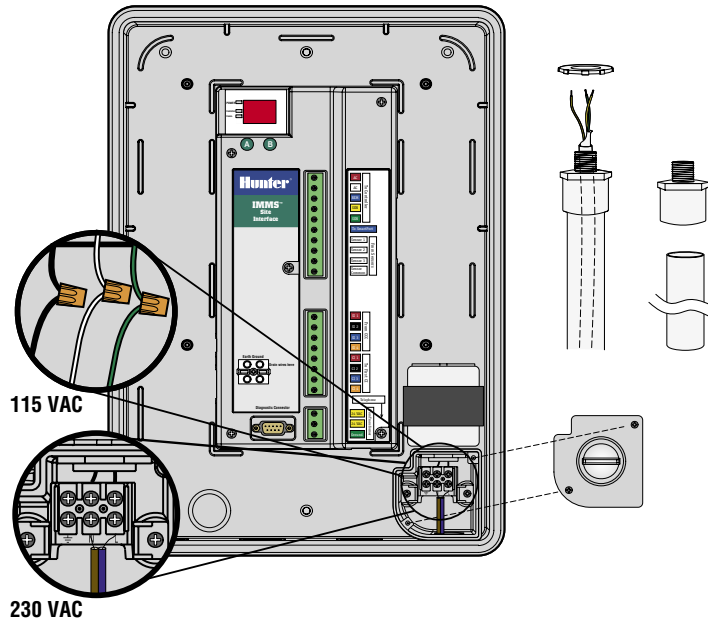

CONNECT INTERFACE TO CONTROLLER.....

1. Use approximately 6 ft. (2 m) of 18 AWG (1 mm) 5-conductor sprinkler wire to connect interface to the controller.
2. Strip wires approximately $\frac{3}{16}$ " (4.5 mm) and attach to interface, by color, at the "To Controller" section of the terminal strips.
3. Route wire (in separate conduit from AC power) to the controller.

CONNECT INTERFACE TO ICC.....

With controller power OFF, strip wire ends approximately $\frac{1}{4}$ " (6 mm) and connect by color code to the ICC power module terminals as shown.

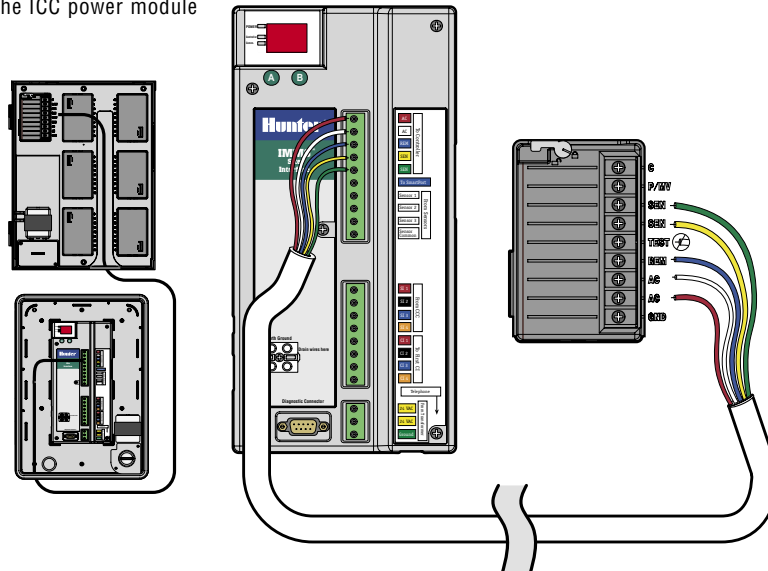

CONNECT INTERFACE TO PRO-C AND SRC.....

With controller power OFF, strip wire ends approximately ¼" (6 mm) and connect by color code to the terminals in the wiring compartment as shown.

To SRC (not shown): With controller power OFF, strip wire ends approximately ¼" (6 mm) and connect by color code to the terminals in the wiring compartment

It is important to connect the red and white wires to the correct AC terminals!

| | |
|---------------|---|
| Red | AC (lower AC power terminal, or leftmost terminal in SRC) |
| White | AC (upper AC power terminal) |
| Blue | Rem (Remote) |
| Yellow | Sen (Sensor) |
| Green | Sen (Sensor) |

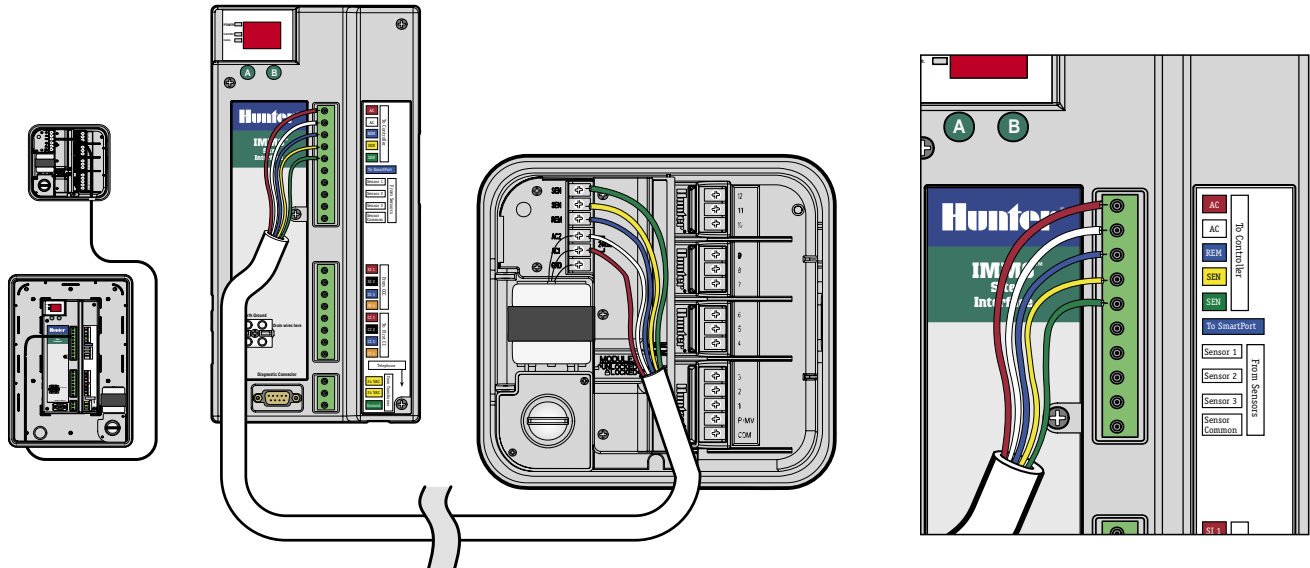

IMMS-SI COMMUNICATIONS CONNECTIONS

IMMS-SI can have two types of communications from the computer. IMMS-SI-HW has hardwired input over GCBL cable, from a CCC installed at the computer. IMMS-SI-MOD connects to a standard telephone jack with a dedicated analog line (must have dial tone).

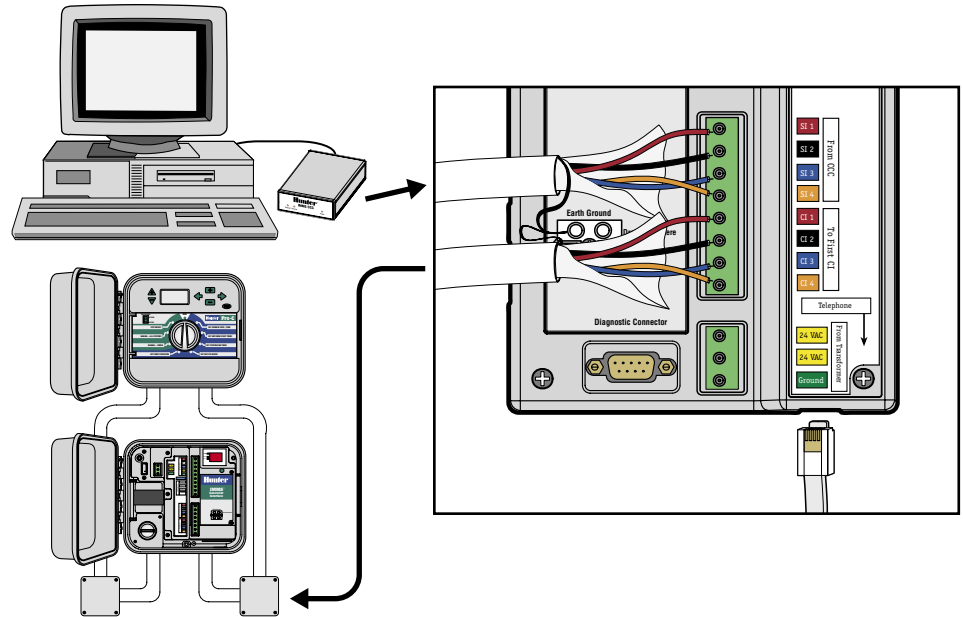

HARDWIRE CONNECTION (IMMS-SI-HW)

1. Route GCBL cable from CCC through low-voltage conduit into SI.
2. Strip black outer jacket and excess foil shield back approximately 2" (50 mm).
3. Strip approximately $\frac{3}{16}$ " (4.5 mm) from each individual wire and connect to top half of communications terminals, in area labeled "From CCC", observing color codes.
4. Connect bare silver ground wire in GCBL to ground lug at earth ground symbol.
5. Connect bare copper 10 AWG (2.5 mm dia.) wire from ground lug to proper earth ground (recommended impedance 10 Ohms or less).

TELEPHONE MODEM CONNECTION (IMMS-SI-MOD)

1. Route RJ-11 telephone cable through low-voltage conduit into SI.
2. Connect straight up into receptacle below terminal strips, indicated by "Telephone" pointer, until "click" indicates the connection is locked into place.
3. Connect other end to service telephone jack. See modem country code selection process in the diagnostics section.

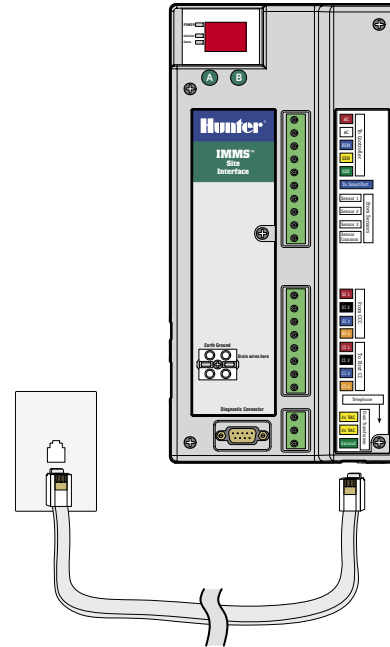

WIRELESS CONNECTION

Refer to instructions included with the optional wireless kit.

EARTH GROUNDING.....

1. Connect bare copper 10 AWG (2.5 mm) Earth Ground wire to grounding terminal where labeled in interface.
2. Route ground wire through low-voltage conduit and secure to 8 ft. (2.5 m) copper-clad ground rod, driven vertically into earth.
3. Ground connection should have recommended resistance of 10 Ohms or less.

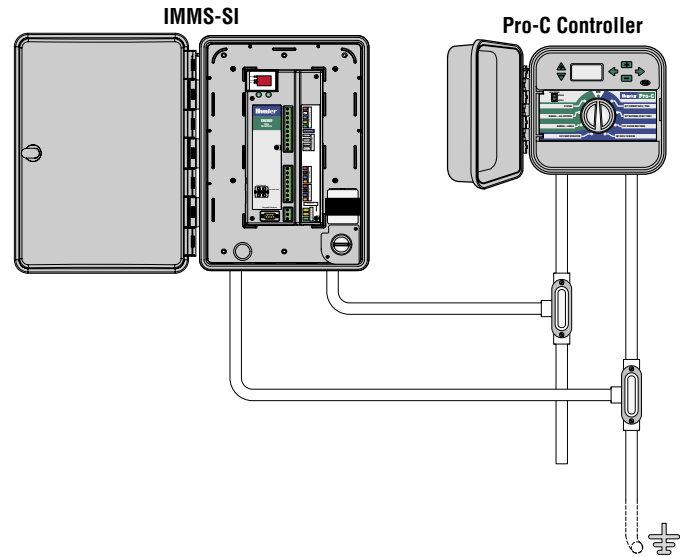

POWER AND TEST.....

Basic connections are complete after these steps. Apply AC power to the interface and observe display. Display should automatically show test pattern, then version number, and then address (always "01" on Site Interface). Blinking red dot shows normal operation. No dot, or constant-on dot, means microprocessor needs to be reset (power off, then back on).

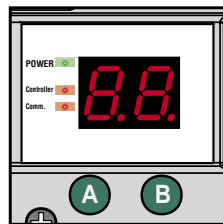

LED lights to the left of the display indicate Power, Controller, and Comm.

- Power shows AC is live to the interface.
- Comm lights when the interface is communicating with the central computer.
- Controller lights after the interface is finished communicating with the computer, and is downloading information into the controller.

A & B BUTTONS.....

The buttons allow the SI to address the Controller Interfaces in the system, and various diagnostic modes.

TO ADDRESS CONTROLLER INTERFACES.....

1. Install all additional CI units in accordance with their instructions (see "Connections to Other Interfaces") and install communications connections.
2. At the SI, press and hold the "B" button for approximately 5 seconds.
3. The display will enter the "racetrack" mode (lights move around perimeter of display). It will remain in this mode until you press "B" again, or until it receives communications from a central computer.
4. With the SI in racetrack mode, visit each CI in order, from the lowest number to the highest number.
5. Press the single green button in the CI once, and the SI will assign it the next available address. Pressing the button causes the SI to see and number the CI.
6. Because the SI is always "01", the first CI will automatically receive address "02". The next CI will receive address "03", etc. When finished with all CIs, return to the SI and press "B" again to exit the racetrack mode and resume normal operations.

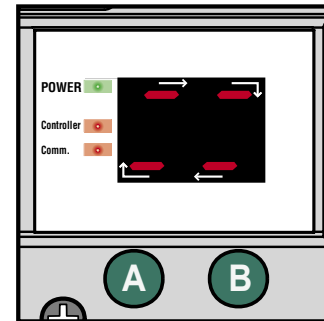

DIAGNOSTICS

There are 4 different diagnostic modes available from the SI buttons. The “A” button is used to select the diagnostic, and “B” is used to execute it.

Run Station. Press and hold “A” for approximately 3 seconds, until “d1” appears. Press the “B” button for 1 second, and station 1 at the controller will run for 1 minute (checks communication between interface and local controller).

Radio check. Press and hold “A” until “d1” appears. Release, and press once again to display “d2”. Press “B” for one second. This will cause the radio to transmit a continuous tone for 5 seconds (verifies operation of radio, no effect in non-radio units).

Check Controller Interfaces. Press and hold “A” until “d1” appears. Release, and press twice to display “d3”. Press “B” for one second. The SI will now “poll” the CI’s in order to verify communications, and each CI address will appear in the display. If a CI does not respond, the display will alternate between the problem CI’s address and the “EE” error display (troubleshoot communications and power to CI). Press “B” once to stop polling and return to normal operations (continuous “01” display).

Configure Modem Country Code. Press and hold “A” until “d1” appears. Release, and press three more times to display “d4”. Press “B” for one second. SI display will be c X, where X equals the country code selection for the telephone modem according to the following table:

The default setting is “c 0” and for most countries this is the correct selection. If your country appears on the following list, change the code display to the number shown:

| Country | Code | | | | |
|----------------|------|-------------|---|--------------|---|
| Australia | 2 | Israel | 1 | Poland | 1 |
| Czech Republic | 3 | Japan | 4 | Singapore | 1 |
| Hong Kong | 1 | North Korea | 1 | Slovenia | 1 |
| Hungary | 1 | Malaysia | 1 | South Africa | 6 |
| India | 1 | New Zealand | 5 | Vietnam | 1 |
| Indonesia | 1 | Philippines | 1 | | |

Press “A” to select country code. When correct code is displayed press “B” for 1 second.

ADDITIONAL CONNECTIONS

Turn off or disconnect AC power plug before making any connections inside the SI!

CONNECTIONS TO OTHER INTERFACES

1. To connect to additional Controller Interfaces, route, strip, and connect GCBL cable to the lower section of the SI communications terminals labeled "To First CI".
2. Connect the bare silver ground wire in the GCBL to the ground lug.
3. Continue the GCBL run to the next interface (IMMS-CI) in one continuous run, if possible, with no breaks or splices in the communications. Refer to CI installation instructions to continue the installation.

CONNECTION TO OPTIONAL CLIK SENSORS

1. Connect only Hunter Clik-family sensors to IMMS. Refer to sensor documentation for correct installation of sensor and permissible wire runs.
2. Route sensor wires into the cabinet through low-voltage conduit, and strip wire ends approximately $\frac{3}{16}$ " (4.5 mm).
3. Connect one wire from sensor to "Sensor 1" position on upper terminal strip.
4. Connect other sensor wire to "Sensor Common".
5. Up to 3 sensors may be connected to the SI. Connect one wire from each additional sensor to terminals "Sensor 2" and "Sensor 3", and connect the other wire from each sensor to the "Sensor Common".

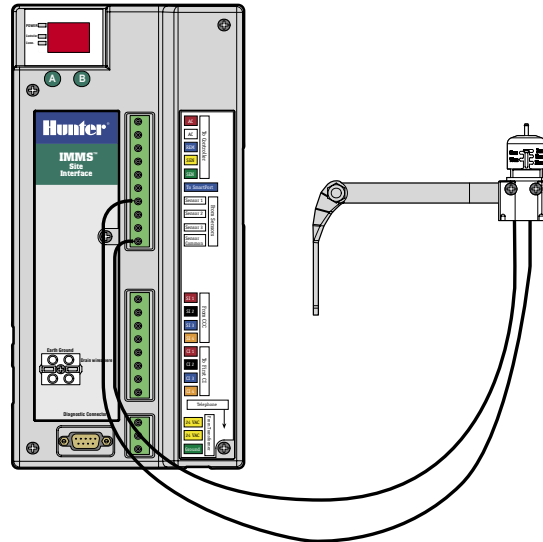

POWERED SENSORS

Hunter's Wireless Rain-Clik™ and the Flow-Clik IMMS require 24VAC power over their yellow wires.

WIRELESS RAIN-CLIK™

1. Route the receiver cable through the low-voltage conduit.
2. Strip and connect the 2 yellow power wires from the sensor receiver to the power terminals in the interface.
3. This will double the yellow wires in each terminal, one each from the interface transformer, and one each from the sensor power.
4. Route and connect the white sensor signal wire to the desired sensor input, and the blue wire to the Sensor Common. The orange wire is not used in an IMMS connection.

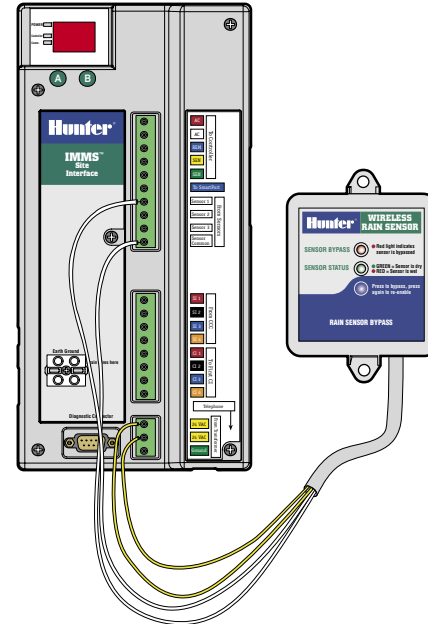

FLOW-CLIK IMMS

1. Route the Flow-Clik™ sensor cable through the low-voltage conduit. Strip and connect the 2 yellow power wires from the sensor receiver to the power terminals in the interface.
2. Connect one of the white wires to the Sensor number, and the other to “Sensor Common”.

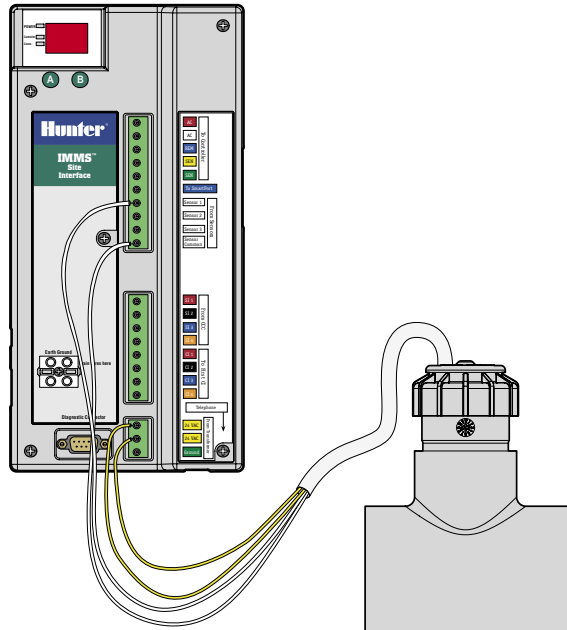

CONNECTION TO OPTIONAL REMOTE RECEIVER (SRR OR ICR)

1. Refer to remote receiver documentation for correct installation of Hunter SmartPort® and permissible wire runs. Connect red and white SmartPort wires to the red and white coded terminals on the upper terminal strip.
2. The red and white wire connections will be doubled, because they are shared with the red and white controller connections.
3. Connect the blue wire from SmartPort to the other blue position labeled, "To SmartPort". The blue SmartPort connection is not shared with any other wires!

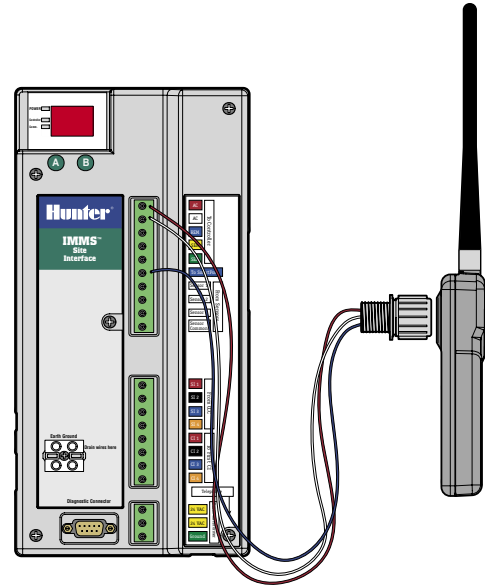

GCBL.....

Two twisted pair (18 AWG/1 mm, orange/blue/black/red), shielded, with ground wire, for direct burial. Used for IMMS interface communications up to 10,000 ft./3 km. Avoid splices in GCBL cable runs.

5 CONDUCTOR SPRINKLER WIRE

18 AWG or 1 mm, red/white/blue/yellow/green. Used to connect interface to local controller up to 6 ft./2 m.

RJ-11 TELEPHONE CABLE

Standard telephone cable, may be used with international jack adapters. Used to connect SI-MOD to telephone line up to 6 ft./2 m.