

FLOW-CLIK

Flow Sensor

Owner's Manual and
Installation Instructions

Version for use with any standard 24 volt controllers

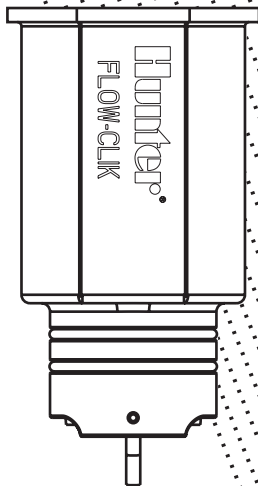

Hunter[®]

TABLE OF CONTENTS

Introduction	1
Flow-Click Components	2
Flow-Click Sensor	2
Flow-Click Sensor Body	2
Flow-Click Interface Box	3
System Status Indicator	4
System Overview and Flow-Click Operation	5
Installing the Flow-Click Sensor Body	9
Installing the Flow-Click Sensor	10
Mounting the Flow-Click Interface Box	11
Wiring the Flow-Click Interface Box to the Controller	12
Wiring When Using Multiple Sensors	14
System Considerations	15
Calibrating the Flow-Click to the Irrigation System.....	16
Setting the Startup Delay	20
Setting the Interrupt Period.....	21
Troubleshooting Guide.....	22
Frequently Asked Questions	25
Specifications.....	27

INTRODUCTION

Shutting down an irrigation system when excess flow occurs provides the benefits of reduced liability, water conservation, erosion prevention and overall reduction in repair costs. Typical causes for over-flow conditions can stem from problems due to ruptures in the main or lateral lines, when heads are broken or removed from the system, or when valves do not shut off automatically.

The Hunter Flow-Clik flow sensor monitors flow to an entire irrigation system or through an individual valve. In the case of an overflow condition, the Flow-Clik will automatically shut down the irrigation system at the controller. The Flow-Clik acts as a switch to break the electrical circuit to the solenoid valves as soon as it registers a flow exceeding a calibrated set limit. This allows the timer to advance as scheduled, but keeps the valve(s) with a “high flow” condition from activating. As a result, of installing the flow sensor in a system, the user gains the benefit of substantially reducing the amount of water loss during an occurrence of an over-flow condition.

FLOW-CLIK COMPONENTS.....

This section will give you a brief overview of some of the components of the Flow-Clik system. Each item will be discussed in further detail later, however, this section can be helpful in getting acquainted with the different options available.

A. Flow-Clik Sensor

1. **Impeller** – rotates when flow is occurring
2. **O-rings** – provides sealing of sensor in sensor body
3. **Wires** – black and red wires connect sensor to Flow-Clik Interface Box

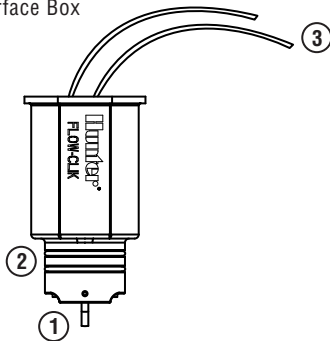

B. Flow-Clik Sensor Body (FCT Series)

4. **Flow-Clik Tee** – the Tee is installed into the irrigation system and houses the Flow-Clik sensor
5. **Plug** – used to seal the body when the sensor is not installed in the sensor body
6. **O-rings** – provides sealing of plug in sensor body
7. **Cap** – retains plug or sensor in sensor body
8. **Cover** – snaps over the top of the sensor

Note: Flow-Clik sensor bodies ordered separately.

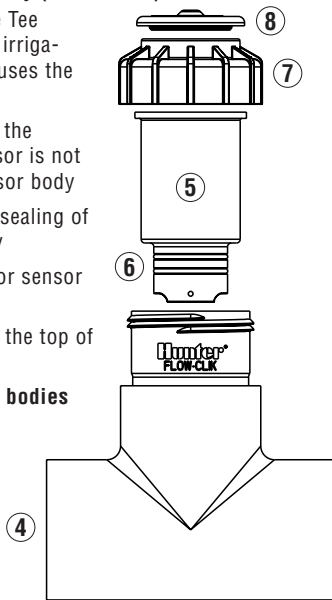

C. Flow-Clik Interface Box

- 9. Startup Delay Rotary Dial** – used to set startup delay and calibrate sensor
- 10. Interrupt Period Rotary Dial** – used to set interrupt period and calibrate sensor
- 11. Restart/Calibrate Button** – used to restart system (when using the “Restart Manually” setting) and calibrate sensor during setup

- 12. System Status Indicator** – provides a visual indication of the Flow-Clik status
- 13. Wires** – black and red wires to Flow-Clik Sensor
- 14. Wires** – yellow wires to AC power terminals at Controller, white wires to sensor terminals or valve common wire at controller

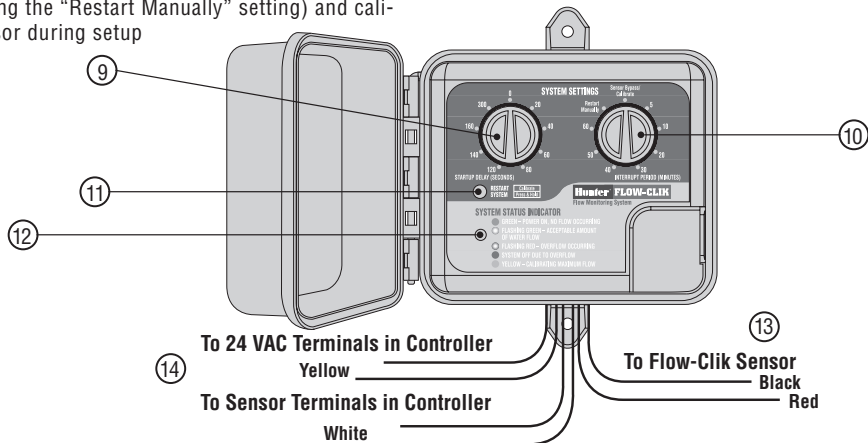

FLOW-CLIK COMPONENTS (continued)

D. System Status Indicator

The Flow-Clik Interface Box has a System Status indicator LED that provides information on the current status of the Flow-Clik system.

GREEN indicates power is applied to the sensor, but no flow is occurring

FLASHING GREEN indicates an acceptable amount of water is flowing (below the flow sensor calibrated maximum)

FLASHING RED indicates that overflow is occurring (Water flow in excess of the calibrated maximum)

RED indicates an unacceptable amount of water was flowing and the system has been shut down. (Water flow exceeded the calibrated maximum for a time period longer than the startup delay).

ALTERNATING RED/GREEN indicates that system overflow occurred during an automatic watering cycle (press the Restart/Calibrate button to reset the system status indicator).

YELLOW indicates that the Flow-Clik is calibrating the sensor to the system flow).

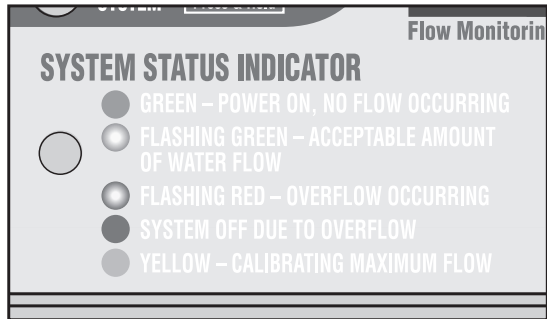

SYSTEM OVERVIEW AND FLOW-CLIK OPERATION

The Flow-Clik System can be installed simply and easily to most standard 24 volt irrigation control systems. The Flow-Clik System consists of the Flow-Clik flow sensor that is installed in the main line or lateral line of an irrigation system, and the Interface Box mounted near the controller to control the operation of the irrigation system. The flow sensor, wired directly to the Interface Box, continually monitors flow occurring within the system and transmits

this data to the Interface Box. The programmable Flow Sensor Interface Box allows the Flow-Clik to function with all Hunter controllers and makes the Flow-Clik compatible with most common irrigation controllers on the market. The Interface Box is used to calibrate the Flow-Clik sensor and set the delay settings for the Flow-Clik. The controller provides the power for the Interface Box, allowing it to send signals continuously to the controller telling it to shut down or start up based upon flow conditions.

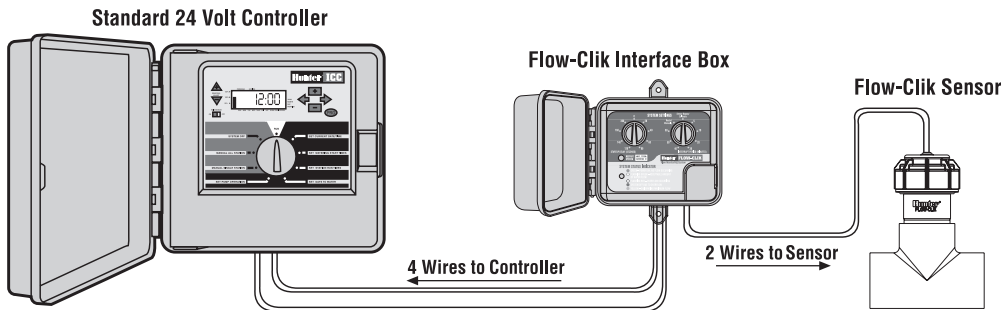

SYSTEM OVERVIEW AND FLOW-CLIK OPERATION (continued)

Example of System Operation

In this illustrative example of a small commercial site, the Flow-Clik sensor is connected to the mainline pipe that provides water to the system control valves. Because it is installed immediately downstream of the master valve, it will provide the added protection of shutting down the irrigation system if a mainline break should occur.

The Flow-Clik can be set to automatically shut off the system whenever actual flow within the system exceeds the flow of the system's highest flow zone. During installation of the Flow-Clik, a calibration procedure (see Calibrating the Flow-Clik) is used to set the Flow-Clik at a level of flow dictated by the highest flow zone. If the system flow exceeds the "calibrated" flow by a pre-determined amount, the Interface Box will signal an overflow condition is occurring.

The figure to the right shows an example of an application using the Flow-Clik sensor. In this example, the valve that commands the highest flow is valve number 4, which has a total flow rate of 18.9 gallons per minute (GPM). The user would turn this valve on and calibrate the Flow-Clik to this zone. If flow exceeds 18.9 gpm, a signal will be sent to the Interface Box which would communicate to the controller

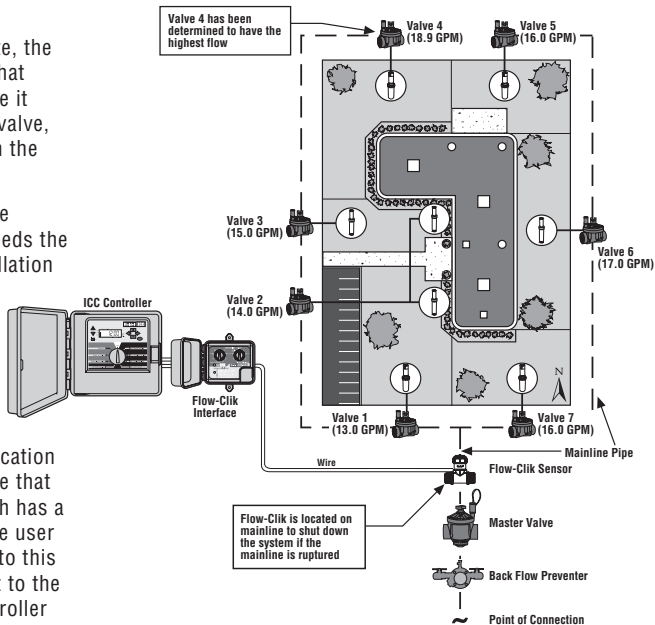

to interrupt the system for a prescribed period of time set by the interrupt delay position on the dial.

The system startup delay and interrupt period can be adjusted by moving the dials on the Flow-Clik Interface Box to the desired settings. The system startup delay allows for system stabilization to occur prior to the Flow-Clik sensing for an overflow condition. The startup delay can be adjusted from 0 to 300 seconds.

The interrupt period setting allows the user to program the Flow-Clik to shut the system off for a prescribed amount of time. The interrupt period can be adjusted by moving the dial to a specified setting from 5 to 60 minutes. There is also a Restart Manually position on the dial that shuts the system off until it is manually restarted at the Interface Box.

In the following example, the startup delay is set for 20 seconds and the interrupt period is set to 10 minutes.

High-Flow Scenario 1 – Valve 3 Lateral Line Breaks

If a lateral line break should occur on valve number 3, the Flow-Clik would sense a “high flow” condition and would shut the system down after a sustained 20 second over flow condition. Once the system has been shut off, the

Flow-Clik will continue to keep the system off for the 10 minutes programmed into the interrupt period. After 10 minutes have passed, the Flow-Clik will turn the system back on and begin to monitor for an over flow condition.

If the run time for zone 3 is 19 minutes and is scheduled to come on at 6:00 am, then the following chain of events would occur:

6:00 AM – Valve 3 is activated and the Flow-Clik senses an over flow condition. After a 20 second delay the system is shut off for 10 minutes.

6:10 AM – Valve 3 is reactivated (it still has 9 minutes of run time left) and after a 20 second delay, a “high flow” condition is again identified and the system is interrupted for another 10 minutes.

6:18 AM – Valve 4 is scheduled to be activated by the irrigation controller, however, the Flow-Clik continues to interrupt system operation due to the 1 minute left on the interrupt delay.

6:20 AM – Valve 4 is activated and the Flow-Clik begins to monitor the flow of valve 4 which is below the “high flow” trigger point enabling the controller to continue to irrigate as it normally would.

SYSTEM OVERVIEW AND FLOW-CLIK OPERATION (continued)

Post 6:20 AM – For the balance of the irrigation cycle flow is monitored by the Flow-Clik without exceeding the maximum and the total irrigation schedule is completed.

The Flow-Clik will continue to shut the system off during automatic operation of valve 3 until the lateral line break is repaired.

High Flow Scenario 2 – Mainline Ruptures

If a mainline ruptures, the Flow-Clik would identify a “high flow” condition approximately 20 seconds after the first valve is activated based upon the irrigation schedule and the master valve would be shut down. Flow would continue to be monitored every 10 minutes and after a sustained 20 second “high flow” condition, the system would be shut off. Each time the system is deactivated by the Flow-Clik the System Status Indicator will show a steady red light. This will occur until the mainline pipe is repaired.

In both of the above scenarios, the “high flow” shut down capability of the Flow-Clik sensor would eliminate the water waste and associated damage to the site that would be caused by the breaks in the irrigation system. In the lateral break scenario, the Flow-Clik halts irrigation of the effected valve while continuing to allow the controller to irrigate the rest of the zones throughout the system.

INSTALLING THE FLOW-CLIK SENSOR BODY

The Flow-Clik sensor body (FCT series) is designed in diameters from 1" to 3". It is installed into the mainline or lateral pipe of the irrigation system. It is important to install the Flow-Clik Sensor Body downstream of the master valve (for mainline installations) or the zone valve (for lateral line installations). Also, it is necessary to install the Sensor Body in an area of low turbulence within the system. Areas of high turbulence will cause erratic readings from the Flow-Clik.



NOTE: For maximum protection against overflow conditions, it is required that a master valve be installed.

The figure below represents a recommended sensor body installation. There must be at least 10 times the pipe diameter of straight pipe upstream of the Sensor Body inlet and at least 5 times the pipe diameter in length of straight pipe downstream of the Sensor Body outlet. This will assure that the Flow-Clik sensor be placed in the optimum position within the irrigation system.

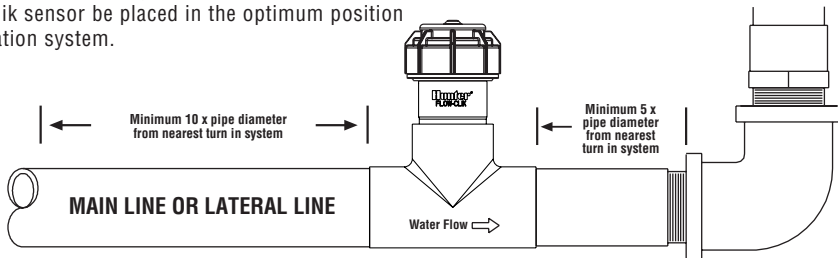

INSTALLING THE FLOW-CLIK SENSOR INTO THE SENSOR BODY

The Flow-Clik Sensor Body comes with a plug that allows for installation of the Sensor Body into the irrigation system prior to installing the Sensor. This allows the sensor body to be installed separate of the sensor and prevents damage to the sensor during installation of the body.



NOTE: Do not attempt to remove the sensor plug or sensor while the system is under pressure

To install the sensor into the body:

1. Turn the system pressure off.
2. Unscrew the cap from the top of the body (figure 1).
3. Use pliers or a screwdriver and carefully pry the plug from the body.

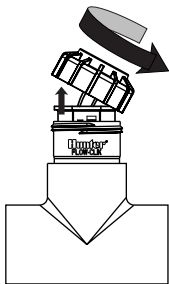

Figure 1

4. Insert the sensor into the sensor body (Check to make sure the two o-rings provided with the sensor are installed in the grooves at the lower end of the sensor). The sensor has a flat side that engages with a flat on the inside of the sensor body (figure 2).
5. Replace the cap on the sensor body (hand tighten only).
6. Feed the two sensor wires through the hole in the cover and snap the cover on the cap.

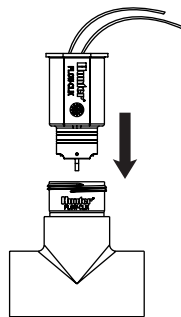
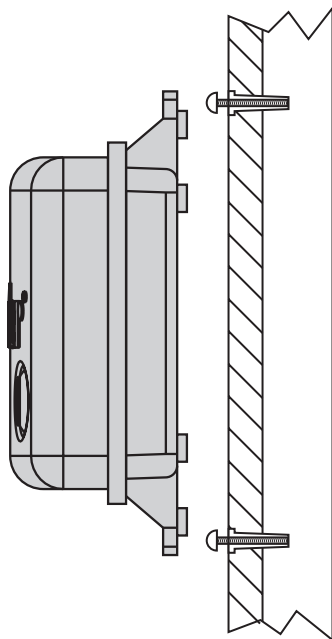

Figure 2

MOUNTING THE FLOW-CLIK INTERFACE BOX.....

The Flow-Clik Interface Box is designed to mount next to the irrigation controller. A door is provided to keep water and debris from entering the inside of the Interface Box. A lock is also provided to prevent unauthorized changes in Flow-Clik settings. There are two mounting tabs on the top and bottom of the Interface Box to provide an easy means to secure it on the wall next to the controller. Using the hardware included, mount the Interface Box to the wall (use screw anchors if needed). Make sure to place the Interface Box close to the controller (check that the controller door and Interface Box door do not interfere with one another).



WIRING THE FLOW-CLIK TO THE IRRIGATION SYSTEM

WARNING! This unit is designed to be installed in conjunction with 24 VAC circuits only. Do not use with 110 or 220 VAC circuits.

Wiring the Sensor to the Interface Box

The red and black leads from the Flow-Clik sensor are connected to the red and black leads on the Interface Box. A minimum wire size of 18-gauge wire can be used to connect the leads from the sensor to the Interface Box. Secure all wire connections with waterproof connectors.

It is recommended that the red and black leads from the Interface Box be routed into the controller. Wire connections for the sensor can be made inside the controller cabinet.



Note: The Flow-Clik Sensor can be installed up to a maximum of 1,000 ft. from the Interface Box when installed with #18 gauge or larger copper wire.

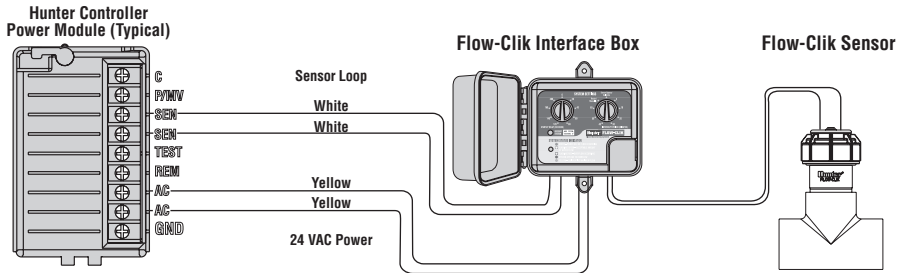

Wiring the Interface Box to the Controller

The Flow-Clik Interface Box is designed to operate similar to most micro-switch type sensors. Hunter controllers have provisions for sensor installations that allow for easy wiring of the Flow-Clik to the controller. The two white wires from the Interface Box are attached to the sensor terminals inside the controller and the two yellow wires are attached directly to a constant 24-volt source.

To wire the Flow-Clik Interface Box on Hunter controllers:

Pro-C and ICC Controller Installations

1. Attach the two yellow wires to the AC terminals on the controller (polarity does not matter).
2. Attach the two white wires to the SEN terminals on the controller.

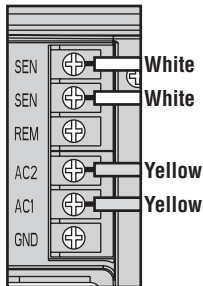

SRC Controller Installations

1. The two yellow wires are connected to the AC terminals on the controller (polarity does not matter).
2. Attach one of the two white wires to the RS terminal on the controller.
3. Attach the other white wire to the “C” terminal.
4. Attach the valve common and pump relay common (if used) to the RS terminal.

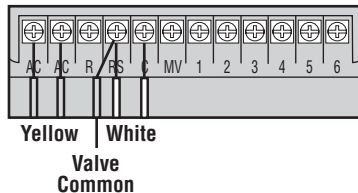

WIRING THE FLOW-CLIK TO THE IRRIGATION SYSTEM (continued)...

Other Controllers

1. Attach the two yellow wires to the AC terminals on the controller (polarity does not matter).
2. Some controllers do not have terminals dedicated for sensor installations. Locate the common wire to the solenoid valves and disconnect it from the common terminal (usually marked "C" on the controller). Attach one white wire from the Flow-Clik Interface Box to the common terminal. Attach the other white wire to the common wire leading to the valves.

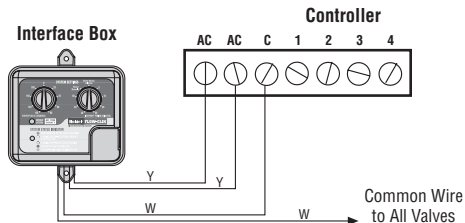

WIRING WHEN USING MULTIPLE SENSORS

The Flow-Clik can be wired to a controller already using another Hunter sensor (i.e. Rain-Clik™, Wind-Clik®, Freeze-Clik®, etc.) or other micro-switch type sensors. It is

important to make sure that, when using multiple sensors, they are connected in series.

Hunter Controllers

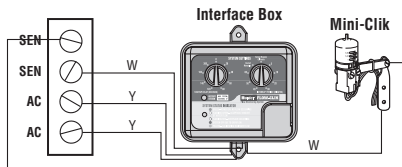

Other Controllers

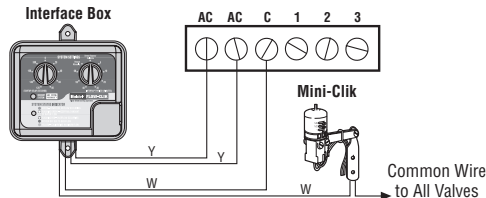

SYSTEM CONSIDERATIONS

Proper irrigation system design and operation assures optimum performance of the Flow-Clik in monitoring for potential high flow conditions. It is important to understand that the Flow-Clik is primarily designed to shut off the irrigation system in the event of a catastrophic system failure such as a main line or lateral line break. However, depending upon the design of the irrigation system, the Flow-Clik can offer increased protection when components such as sprays or rotors are damaged or removed due to vandalism. The following may be helpful in making your Flow-Clik System operate at its optimum level.

Proper Irrigation System Design

Generally, the Flow-Clik is designed to shut off the irrigation system when a high flow condition is identified. A high flow occurs when the actual flow rate through the system exceeds the “learned” flow of the highest flow zone. If a wide variation in flow rates exist between the highest flow zone and the lowest flow zone, the Flow-Clik may not sense an over flow condition if damage occurs within the low flow zone(s). For example, if an irrigation system has a rotor zone that operates at 18.9 GPM, and a drip zone that flows at 5 GPM; any damage to the drip zone components may not result in high enough flow rate for the Flow-Clik to sense an over flow condition.

The more balanced the irrigation system is designed, the more protection will be provided by the Flow-Clik. Zones should be designed so that they operate at similar flow rates.



Note: To assure proper operation, the flow for the highest flow zone should not exceed 75% of the maximum system flow.

Mainline Pressure Fluctuation

Some water sources may have varying pressure depending upon the demand for water upstream of the point of connection. During times of heavy demand, system pressure through the mainline may drop. A decrease in mainline pressure will result in a decrease in flow rates throughout the system. If the Flow-Clik calibration procedure takes place during a period of time which pressure is at its lowest point, an increase in pressure at the point of connection may result in system flow rates that exceed the calibrated “high flow”. As a result, the Flow-Clik may shut the system down prematurely even though the system is functioning normally.

SYSTEM CONSIDERATIONS (continued).....



Note: If pressure fluctuations at the point of connection in excess of 10 psi are expected, it is recommended that a pressure regulator be installed on the mainline or at the master valve.

Proper System Maintenance and Operation

It is important that your irrigation system be maintained and is functioning properly for optimum performance. Check your irrigation system for any broken components or leaks also, make sure that all sprinklers are operating within the pressure ranges recommended by the manufacturer.

CALIBRATING THE FLOW-CLIK TO THE IRRIGATION SYSTEM



Note: Before calibrating the Flow-Clik to your system, it is very important that the irrigation system be in good working condition. Irrigation system leaks, broken sprinklers, zones operating outside specified pressure ranges, will have a negative effect on the performance of the Flow-Clik.

Using the Flow-Clik's Interface Box, the sensor is calibrated by pressing the Calibrate button while the highest flow zone is operating. While the system is "learning" the flow, the System Status Indicator light will be yellow. After a 10 second period of "learning" it will begin to monitor system flow.

If you already know the highest flow zone within the system:

1. Turn the Startup Delay dial to the 0 second position.
2. Turn the Interrupt Period dial to the Sensor Bypass/ Calibrate position.
3. Manually activate the zone with the highest flow.
4. While the zone is operating, press and hold the Calibrate button on the Interface Box. The System Status Indicator light will change to yellow indicating that the sensor is being calibrated to the zone(s) operating. Release the calibrate button. Once the Flow-Clik has finished "learning" the system's high flow zone, the light will turn to flashing green which means that the calibration process is complete.

5. Turn the irrigation system off and set the Startup Delay and Interrupt Period settings on the Interface Box (see Setting the Startup Delay and Interrupt Period).

If you do not know the highest flow zone within the system:

Flow Estimate Calibration Method

In some cases, you may not know the zone with the highest flow. A guideline that will help you easily determine which zone valve has the highest flow (GPM) is to count the number of sprinklers on each zone. If there are zones with both sprays and rotors operating in the irrigation system, you can multiply each spray head by 2.0 GPM, each medium range rotor by 4.0 GPM, and each large range rotor by 15.0 GPM for a general estimate of total flow for each zone.

For a more accurate determination of total flow for each zone, it is recommended that you measure the nozzle pressure at each sprinkler zone and then look up the nozzle flow at that specific pressure in the nozzle performance data section of the manufacturer product catalog. Once a determination is made of the highest flow zone, you can use the procedure above to calibrate the Flow-Clik to the system.

For example, Figure 1 (on the following page) shows a typical zone using I-20 rotors. To estimate the total flow of the zone:

1. Determine the approximate water pressure at the base of the sprinklers in each zone while the system is operating. In the illustrative example it has been determined that the sprinkler pressure in zone 4 is 50 psi.
2. Identify the model of sprinkler and its associated nozzle for each valve. Valve 4 has Hunter I-20 rotors that have various nozzles based on the distance of throw and the arc of coverage needed. For reference, the quantities of each type of sprinkler and nozzle configuration for zone 4 is identified in the attached irrigation legend.
3. Determine the flow rate for each sprinkler and nozzle configuration. Based upon information found in the Hunter Catalog the associated flows for each Hunter I-20 sprinkler and nozzle configuration is listed in the attached irrigation legend.
4. Determine the total flow of all sprinklers on the zone. The total flow of zone 4 in this example is 18.9 GPM as identified in the irrigation legend.

CALIBRATING THE FLOW-CLIK TO THE IRRIGATION SYSTEM (cont.)

Manual Cycle Method

You can also use your controller to help calibrate the Flow-Clik in a system with unknown flow rates among zones.

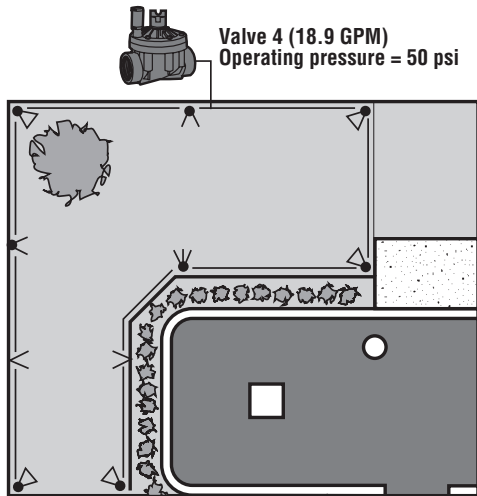

Figure 1

This method is easy, accurate and prevents the user from having to count and estimate system zone flows. Simply operate your controller manually and sequentially “learn” as you cycle through each of the zones.

To calibrate the Flow-Clik with the Manual Cycle Method:

1. Turn the Startup Delay dial to the 0 second position.

Symbol	Sprinkler Description	*Flow @ 50 psi	Qty	Total Flow
●◁	Hunter I-20-ADS – 1.5	1.6	x 3	= 4.8
●◁	Hunter I-20-ADS – 3.0	2.7	x 2	= 5.4
●◁	Hunter I-20-ADS – 4.0	4.2	x 1	= 4.20
◁	Hunter I-20-ADS – .75SR	.75	x 2	= 1.50
<	Hunter I-20-ADS – 1.5SR	1.5	x 2	= 3.0

Total Flow = 18.9 GPM

*Information obtained from the Hunter catalog

Figure 1 Legend

2. Turn the Interrupt Period dial to the Sensor Bypass/ Calibrate position.
3. Start a manual cycle on the controller beginning with the first zone (for Hunter controllers, use the One Touch Manual Advance feature).
4. Press and hold the Flow-Clik Calibrate button on the Interface Box for 5 seconds. The System Status Indicator will change to yellow indicating that the Flow-Clik is “learning” the flow of the zone. Release the button when the yellow light appears. When finished calibrating, the System Status Indicator will begin to flash green.
5. Advance the controller sequentially to the next zone. Wait a few seconds for a change in the System Status Indicator. If the indicator begins flashing red, repeat Step 4. If the indicator continues to flash green, advance the controller to the next zone.
6. Repeat until all zones have been checked.
7. Set the Startup Delay and Interrupt Period settings on the Interface Box (see Setting the Startup Delay and Interrupt Period).



Note: If your controller is programmed to operate more than one zone at a time, those zones will have to be activated together to calibrate the Flow-Clik to total system flow.

SETTING THE STARTUP DELAY

The high velocities that are common during initial activation of an irrigation cycle could cause the Flow-Clik to sense a “high flow” situation (primarily due to air trapped within the system) and subsequently shut down the irrigation system at the beginning of every cycle. The Flow-Clik addresses the problem by providing a programmable Startup Delay to allow the system to stabilize prior to the Flow-Clik monitoring for high flow conditions. To program the Startup Delay, turn the dial on the left side of the Interface Box to one of the eight preset delay positions from 20 seconds to 300 seconds.

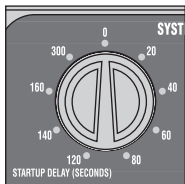

Note: The 0 second delay position is used for calibration of the Flow-Clik during initial installation only (see page 16).



Note: The startup delay required may vary between zones. Select the largest start up delay required for all zones.

SETTING THE INTERRUPT PERIOD.....

The Flow-Clik monitors for a high flow condition, shutting down the system or individual zone when overflow occurs. Once the system has been shut off due to a high flow condition, the Flow-Clik turns the system back on automatically after a pre-selected amount of time has passed. By waiting out a selected amount of time allows for the system to resume watering areas that may not be affected by the “problem.”

The Interface Box offers nine pre-selected off times from 5 to 60 minutes that are programmable by a single rotary switch. To set the Interrupt Period, turn the dial on the right of the Interface Box to the desired period of time you would like the Flow-Clik to keep the system off after a high flow condition has occurred before continuing to irrigate.

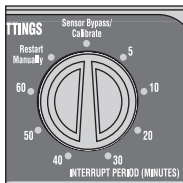

Example: A system that is mostly spray zones set for 10 minute run times could select a delay of 10 minutes so the system is only off during the operation if a single zone.

Manual Restart Feature

If the dial is set to the Restart Manually position, and an over flow condition is detected by the Flow-Clik, irrigation will not resume until the system has been manually reset.

To manually restart the system after an overflow condition has occurred:

Press the Restart System button once on the Interface Box. The System Status indicator light will change from red to green or flashing green (if flow is occurring).

Sensor Bypass

The Sensor Bypass setting allows the user to manually override the Flow-Clik sensor. This is helpful during situations that require the system to operate at higher than “learned” flow rates (i.e. system winterization, running a hose bib, or operating multiple valves). To bypass the Flow-Clik sensor, turn the interrupt period dial to the Sensor Bypass/Calibrate position. If the sensor experiences an overflow condition, the system status indicator will identify the overflow, but the interface box will continue to allow the controller to operate.

TROUBLESHOOTING GUIDE

PROBLEM	CAUSE	SOLUTION
System Status Indicator light is off	No AC power to the Flow-Clik Interface Box	A) Check that the Interface Box power leads (yellow wires) are attached to the 24 VAC terminals on the controller. B) Verify that the power to the controller is on.
System Status Indicator light is flashing red	Irrigation system is in an overflow condition	Normal operation during an overflow condition. The Flow-Clik has identified overflow condition and is waiting the pre-set startup delay period before shutting the system off.
System Status Indicator is steady red	Irrigation system is in an overflow condition	Normal operation during an overflow condition. A) The Flow-Clik has identified an overflow condition and is waiting the predetermined amount of time set as the Interrupt Period before restarting the irrigation cycle. B) The Interrupt Period setting is in the Manual Restart position requiring that the Flow-Clik be reset before irrigation can resume. Press the Restart System button to reactivate the Flow-Clik.

<p>Flow-Clik will not shut the irrigation system off</p>	<p>No power to Flow-Clik</p> <p>Faulty wire connections from the Flow-Clik sensor to the Interface Box</p> <p>System has not reached an overflow condition</p> <p>System is in the Startup Delay mode</p>	<p>Check System Status Indicator light is on (if light is off, see above).</p> <p>Check Flow-Clik sensor wires (red and black wires) are properly connected.</p> <p>A) Normal operation.</p> <p>B) System is not balanced. Too much variation between flow rates of the zones may prevent the Flow-Clik from sensing an overflow condition on the lower flow zone(s). Flow-Clik will only shut the system down if flows exceed highest flow zone.</p> <p>Wait for start up delay period to end.</p>
<p>Flow-Clik continually shuts off a zone with no known problems</p>	<p>Flow-Clik is improperly calibrated</p> <p>High fluctuations in system pressure</p>	<p>Reset the Flow-Clik to the highest flow zone.</p> <p>It is recommended that the Flow-Clik be set at the time of day that the irrigation system will be run. Note: If too much pressure fluctuation occurs, it may be necessary to add pressure regulation to the system.</p>

TROUBLESHOOTING GUIDE (continued)

System Status Indicator light is not Flashing Green when the system is running	Faulty wiring connections from the Flow-Clik sensor to the Interface Box AC power not being supplied to the Interface Box Debris is stuck in the impeller of the Flow-Clik sensor	Check Flow-Clik sensor wires (red and black wires) are properly connected. Check the wiring connections from the controller to the Interface Box. Confirm that system pressure is off. Remove cap and pull sensor out of the sensor body and inspect for debris or damage to the impeller.
System Status Indicator is Flashing Red/Green	System experienced an overflow condition during an automatic watering cycle.	Manually cycle system to find cause of system overflow. Press the Restart/Calibrate button to reset the system status indicator.

FREQUENTLY ASKED QUESTIONS

What is the ideal location for a Flow-Clik sensor in my irrigation system?

If your system is balanced (similar flow rates among all zones), the best position for the Flow-Clik sensor would be just downstream of the master valve in your system. Make sure the sensor is at least 10 times the pipe diameter in distance away from the outlet of the master valve.

Do I need a master valve to use the Flow-Clik?

The use of a master valve is preferred when installing a Flow-Clik in your system. The Flow-Clik is designed to prevent water loss due to catastrophic failure of your irrigation system. If a master valve is used at the beginning of the mainline, the Flow-Clik can provide maximum protection in shutting off the system when mainline ruptures occur.

My controller is running two valves at one time. Is this a problem?

No. The Flow-Clik is designed to be calibrated to your highest flow zone(s). If you are operating more than one valve with your controller, both valves need to be operating at the same time during Flow-Clik calibration and setup.

Should I be concerned about winterization with the Flow-Clik?

Typically, systems are winterized using compressed air to “blow out” the water in a system. Depending upon the location of the Flow-Clik sensor in the irrigation system, it may sense a “high flow” condition due to air moving the sensor at a very high rate. It is recommended that the Flow-Clik be shut off before winterization by using the sensor bypass switch at the controller to deactivate the sensor.

Can I use one Flow-Clik sensor with two irrigation controllers on the same system?

No. The Flow-Clik is designed so that each sensor has an Interface Box that attaches to each specific controller. Controllers cannot share the Interface Box.

Can I use multiple Flow-Clik sensors on the same system?

Yes. Flow-Clik sensors can be installed on multiple lateral lines within your irrigation system for a higher level of overflow protection. However, each sensor would require its own Interface Box at the controller and would need to be wired in series with one another.

FREQUENTLY ASKED QUESTIONS

How long will the Flow-Clik keep my system off if an overflow condition occurs?

The Flow-Clik Interface Box allows the user to customize the Flow-Clik operation based upon the specific system. The Flow-Clik Interface Box provides for 9 pre-set Interrupt delay positions from 5 to 60 minutes that are set by the user. There is also a manual re-start position that requires the user to manually re-start the irrigation system at the Interface Box if an overflow condition has shut the system off.

How do I know my Flow-Clik is working?

The Flow-Clik Interface Box has a System Status Indicator that provides information on the status of your Flow-Clik. Reference page 4 of this manual.

Will I lose my controller settings if the Flow-Clik shuts my system off due to an overflow condition?

No, the Flow-Clik switches off the solenoid valves of the irrigation system when it senses an overflow condition. This prevents flow of water to the sprinklers without affecting the operation of the timer. Once the Flow-Clik has reached the end of the Interrupt Period programmed into the Interface Box, the valves resume normal operation.

SPECIFICATIONS

Models

Operating Specifications

Temperature: 0 to 150 degrees F

Pressures: up to 200 psi

Humidity: up to 100%

Additional Features

Programmable Start Up Delay (0 to 300 seconds)

Programmable Interrupt Period (5 to 60 minutes)

System Status Indicator Light

One Button System Calibration

FLOW RANGE			
FLOW SENSOR DIAMETER	OPERATING RANGE (GPM)		
	MINIMUM*	SUGGESTED MAXIMUM**	MAXIMUM
1"	6	17	50
1½"	13	35	100
2"	20	55	200
3"	50	120	300

* Minimum recommended flow for the highest flow zone for your system

** Good design practice dictates the maximum flow not to exceed 5ft/sec.
Suggested maximum flow is based upon Class 200 IPS plastic pipe

Electrical Specifications

Current Draw: (@ 24 VAC) .025 amps

Switching Current: 2.0 amps

Maximum Distance between Interface Box and Sensor = 1,000 ft.

Dimensions

Flow-Clik Interface Box (4.5"H x 5.5"W x 1.5"D)

Flow-Clik Sensor Body (FCT Series)

FCT 100 (4.8"H x 2.3"W x 4.5"L)

FCT 150 (5.4"H x 2.3"W x 4.6"L)

FCT 158 (5.4"H x 2.3"W x 5.1"L)

FCT 200 (5.9"H x 2.7"W x 4.7"L)

FCT 208 (6.0"H x 2.9"W x 5.4"L)

FCT 300 (7.0"H x 4.0"W x 6.2"L)

FCT 308 (7.0"H x 4.2"W x 6.4"L)

Hunter Industries Incorporated • The Irrigation Innovators

1940 Diamond Street • San Marcos, California 92069

www.HunterIndustries.com

© 2003 Hunter Industries Incorporated

P/N 700973 LIT-366 7/03