

I-90 ADV & 36V Nozzle Installation

Caution! The riser assembly is under spring tension. Eye protection should be worn and proper procedures followed when servicing this product.

Tools needed: Phillips screwdriver, riser service tool P/N 279600, needle-nose pliers.

Preparation

Unscrew the body cap from the body, then withdraw the riser from the body. Place the riser assembly's lower end into the base of riser service tool P/N 279600. Press the tool's metal bar down over the riser spring until the bar enters the slots in the tool's base. Rotate the bar to engage with the tool's base, thereby holding the spring under tension.

Nozzle Removal and Replacement

Remove the logo cap, which is retained by a central Phillips screw. The nozzle is retained in the nozzle housing by a setscrew. To remove the nozzle, back out the setscrew using the hex key on the Hunter wrench so that the nozzle will clear. Grasp the nozzle with pliers and pull to remove.

Insert the replacement nozzle in the housing. Press firmly to fully seat the nozzle so that it will clear the retaining setscrew. Using the hex key on the Hunter wrench, turn the setscrew down to retain the nozzle.

Note: When changing from one nozzle number to another, check the stator for proper setting before returning the head to service.

Stator Ring Installation

Note: When installing nozzles you must also correctly set the stator to ensure proper speed of rotation. Failure to correctly set the stator may cause a non-rotation condition.

The stator is located in the base of the riser assembly. First remove the riser assembly from the body. Then remove the filter screen to access the stator.

The stator has a protruding tab that aligns with a pointer. Remove the stator by grasping this tab with pliers and pulling. Replace the stator so that its pointer is set to the number agreeing with the nozzle installed. Refer to the Nozzle / Stator Chart below for nozzle and stator settings.

Visually check for proper assembly of nozzles, setscrews and stator. Reverse the preparation procedure to reassemble the unit.

Precipitation Rate Adjustment

If you have excessively wet or dry areas, you can change the nozzle in the sprinkler to increase or decrease the precipitation rate. For dry areas, install a larger nozzle. For wet areas, install a smaller nozzle.

I-90 ADV Only – Arc Adjustment

Adjustable heads are preset to approximately 180°. Sprinklers may be adjusted with water on or off. It is recommended that initial adjustment be made before installation.

Rotate the nozzle turret clockwise to the right stop. This is the fixed side of the arc. The nozzle turret must be held in this position for arc adjustments. The right stop does not change.

To Increase Arc:

1. Insert the plastic key end of the Hunter wrench into the adjustment socket (Fig. 1 & 2).
2. While holding the nozzle turret at the right stop, turn the wrench clockwise. Each full 360° turn of the wrench increases the arc 45°.
3. Adjust to any arc between 40° and 360°. The wrench will stop turning, or there will be a ratcheting noise, when the maximum arc of 360° (full circle) has been reached.

To Decrease Arc:

1. Insert the key end of the Hunter wrench into the adjustment socket (Fig. 1 & 2).
2. While holding the nozzle turret at the right stop, turn the wrench counterclockwise. Each full 360° turn of the wrench will decrease the arc 45°.
3. Adjust to any arc between 40° and 360°. The wrench will stop turning, or there will be a ratcheting noise, when the minimum arc of 40° has been reached.

Note: It is not necessary to disassemble the sprinkler to make adjustments.

I-90 Riser Assembly

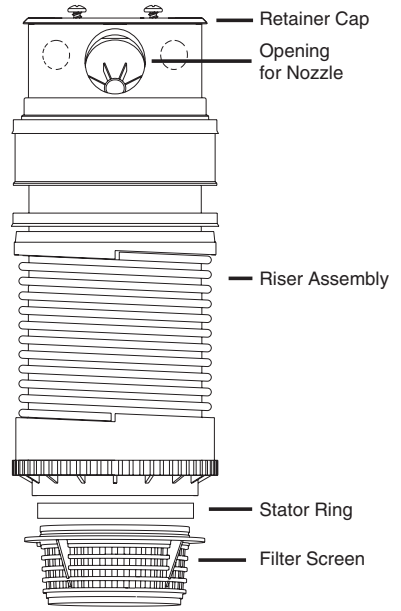

Nozzle / Stator Chart	
Nozzle Number	Stator Position
33	33
38	38
43	43
48	48
53	53
63	63

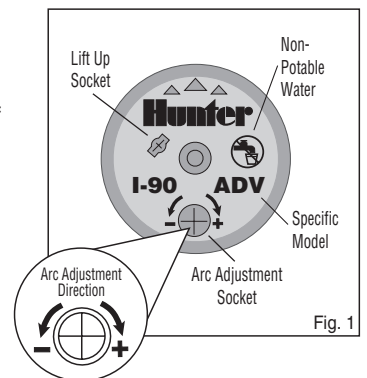

Fig. 1

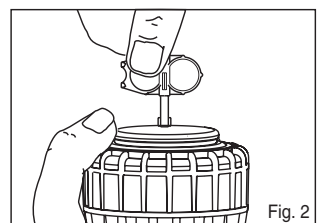













Fig. 2

I-90 ADV Only – Aligning the Right (Fixed) Side of the Arc







If the right side of the arc is not properly aligned, the result may be a wet walkway or a dry turf area. The right side can easily be realigned. One way to realign the right stop is to unscrew the body cap counterclockwise and remove the internal assembly from the body. Once removed, rotate the nozzle turret to the right stop, insert the internal assembly back into the body with the nozzle aligned to the right side of the area you want irrigated. At this point you realigned the right arc stop, and you can adjust the left arc to an appropriate setting.







Performance Charts

I-90-ADV Nozzle Performance Data					
Nozzle	Pressure PSI	Radius ft.	Flow GPM	Precip in/hr	
				■	▲
 33 Gray	60	67'	30.7	1.32	1.52
	70	67'	33.1	1.42	1.64
	80	68'	35.5	1.48	1.71
	90	69'	37.7	1.52	1.76
	100	70'	39.8	1.56	1.81
 38 Red	60	69'	34.0	1.37	1.59
	70	70'	36.9	1.45	1.67
	80	72'	39.8	1.48	1.71
	90	73'	42.3	1.53	1.76
	100	75'	44.1	1.51	1.74
 43 Dk. Brown	60	70'	38.7	1.52	1.76
	70	71'	42.0	1.60	1.85
	80	72'	44.5	1.65	1.91
	90	73'	47.6	1.72	1.99
	100	73'	48.3	1.74	2.01
 48 Dk. Green	70	75'	47.0	1.61	1.86
	80	77'	50.2	1.63	1.88
	90	79'	53.3	1.64	1.90
	100	81'	56.0	1.64	1.90
	 53 Dk. Blue*	70	79'	48.5	1.50
80		81'	53.4	1.57	1.81
90		85'	57.0	1.52	1.75
100		86'	59.5	1.55	1.79
 63 Black**		70	84'	60.9	1.66
	80	86'	63.8	1.66	1.92
	90	88'	66.5	1.65	1.91
	100	90'	69.8	1.66	1.92

I-90-ADV Nozzle Performance Data – Metric							
Nozzle	Pressure Bars	Pressure kPa	Radius m	Flow m ³ /hr	Flow l/min	Precip mm/hr	
						■	▲
 33 Gray	4.1	413	20.4	6.97	116.2	33	39
	4.8	482	20.4	7.52	125.3	36	42
	5.5	551	20.7	8.06	134.4	38	43
	6.2	620	21.0	8.56	142.7	39	45
	6.9	689	21.3	9.04	150.6	40	46
 38 Red	4.1	413	21.0	7.72	128.7	35	40
	4.8	482	21.3	8.38	139.7	37	43
	5.5	551	21.9	9.04	150.6	38	43
	6.2	620	22.3	9.61	160.1	39	45
	6.9	689	22.9	10.02	167.0	38	44
 43 Dk. Brown	4.1	413	21.3	8.79	146.5	39	45
	4.8	482	21.6	9.54	159.0	41	47
	5.5	551	21.9	10.11	168.4	42	48
	6.2	620	22.3	10.81	180.2	44	50
	6.9	689	22.3	10.97	182.8	44	51
 48 Dk. Green	4.8	482	22.9	10.67	177.9	41	47
	5.5	551	23.5	11.40	190.0	41	48
	6.2	620	24.1	12.11	201.7	42	48
	6.9	689	24.7	12.72	212.0	42	48
	 53 Dk. Blue*	4.8	482	24.1	11.02	183.6	38
5.5		551	24.7	12.13	202.1	40	46
6.2		620	25.9	12.95	215.7	39	45
6.9		689	26.2	13.51	225.2	39	45
 63 Black**		4.8	482	25.6	13.83	230.5	42
	5.5	551	26.2	14.49	241.5	42	49
	6.2	620	26.8	15.10	251.7	42	48
	6.9	689	27.4	15.85	264.2	42	49

* Factory-installed nozzle ** Preliminary performance data
Note: All precipitation rates are calculated for 180-degree operation.

I-90-36V Nozzle Performance Data					
Nozzle	Pressure PSI	Radius ft.	Flow GPM	Precip in/hr	
				■	▲
 33 Gray	60	71'	29.8	0.57	0.66
	70	74'	32.2	0.57	0.65
	80	76'	34.4	0.57	0.66
	90	78'	36.8	0.58	0.67
	100	80'	38.6	0.58	0.67
 38 Red	60	74'	33.3	0.59	0.68
	70	77'	36.1	0.59	0.68
	80	79'	38.4	0.59	0.68
	90	80'	40.9	0.62	0.71
	100	82'	42.8	0.61	0.71
 43 Dk. Brown	60	77'	38.1	0.62	0.71
	70	79'	40.9	0.63	0.73
	80	82'	43.9	0.63	0.73
	90	83'	46.5	0.65	0.75
	100	84'	48.5	0.66	0.76
 48 Dk. Green	70	82'	46.3	0.66	0.77
	80	86'	49.6	0.65	0.75
	90	89'	52.5	0.64	0.74
	100	90'	54.8	0.65	0.75
	 53 Dk. Blue*	70	85'	50.5	0.67
80		88'	53.5	0.66	0.77
90		90'	57.4	0.68	0.79
100		92'	59.5	0.68	0.78
 63 Black**		70	90'	60.6	0.72
	80	92'	63.2	0.72	0.83
	90	94'	65.9	0.72	0.83
	100	96'	69.4	0.72	0.84

I-90-36V Nozzle Performance Data – Metric							
Nozzle	Pressure Bars	Pressure kPa	Radius m	Flow m ³ /hr	Flow l/min	Precip mm/hr	
						■	▲
 33 Gray	4.1	413	21.6	6.77	112.8	14	17
	4.8	482	22.6	7.31	121.9	14	17
	5.5	551	23.2	7.81	130.2	15	17
	6.2	620	23.8	8.36	139.3	15	17
	6.9	689	24.4	8.77	146.1	15	17
 38 Red	4.1	413	22.6	7.56	126.0	15	17
	4.8	482	23.5	8.20	136.6	15	17
	5.5	551	24.1	8.72	145.3	15	17
	6.2	620	24.4	9.29	154.8	16	18
	6.9	689	25.0	9.72	162.0	16	18
 43 Dk. Brown	4.1	413	23.5	8.65	144.2	16	18
	4.8	482	24.1	9.29	154.8	16	19
	5.5	551	25.0	9.97	166.2	16	18
	6.2	620	25.3	10.56	176.0	17	19
	6.9	689	25.6	11.02	183.6	17	19
 48 Dk. Green	4.8	482	25.0	10.52	175.2	17	19
	5.5	551	26.2	11.27	187.7	16	19
	6.2	620	27.1	11.92	198.7	16	19
	6.9	689	27.4	12.45	207.4	17	19
	 53 Dk. Blue*	4.8	482	25.9	11.47	191.1	17
5.5		551	26.8	12.15	202.5	17	20
6.2		620	27.4	13.04	217.3	17	20
6.9		689	28.0	13.51	225.2	17	20
 63 Black**		4.8	482	27.4	13.76	229.4	18
	5.5	551	28.0	14.35	239.2	18	21
	6.2	620	28.6	14.97	249.4	18	21
	6.9	689	29.3	15.76	262.7	18	21

* Factory-installed nozzle ** Preliminary performance data
Note: All precipitation rates are calculated for 360-degree operation.